

UNIT V - MOMENT DISTRIBUTION METHOD

Distribution and carryover of moments – Stiffness and carry over factors – Analysis of Continuous beams – Plane rigid frames with and without sway – Naylor's simplification.

TECHNICAL TERMS

5.1 DISTRIBUTION AND CARRY OVER OF MOMENTS

5.2 STIFFNESS AND CARRY OVER FACTORS

5.2.1 Moment distribution procedure

5.3 ANALYSIS OF CONTINUOUS BEAMS

5.3.1 Sinking of supports

5.4 PLANE RIGID FRAMES WITHOUT SWAY

5.5 PLANE RIGID FRAMES WITH SWAY

5.6 NAYLOR'S SIMPLIFICATION

TECHNICAL TERMS

Fixed end moments:

All members of a given frame are initially assumed fixed at both ends. The loads acting on these fixed beams produce fixed end moments at the ends.

Distribution factor:

The ratio between relative stiffness of a member and the total relative stiffness of the joint.

Carryover factors:

Unbalanced moments are carried over to the other end of the member when the joint is released.

Relative stiffness:

When structural elements are linked so that their displacements are equal, they resist loads in proportion to their stiffness.

Frames:

Frames usually consist of post and beam or slab and wall systems, but can also be configured using combinations of structural members.

Sway:

The side movement of the end of a column in a frame.

5.1 DISTRIBUTION AND CARRY OVER OF MOMENTS

Fundamental propositions:

(a) Fixed end moments:

All members of a given frame are initially assumed fixed at both ends. The loads acting on these fixed beams produce fixed end moments at the ends. These moments are exerted by the supports on the beam ends. These moments keep the rotations at the ends of each member zero.

(b) Stiffness:

Stiffness is generally taken as the force required to produce a unit displacement. It is also the moment required to produce unit rotation at a specified point in a structure. It can be extended to denote the torque needed to produce unit twist. Stiffness is usually denoted as k .

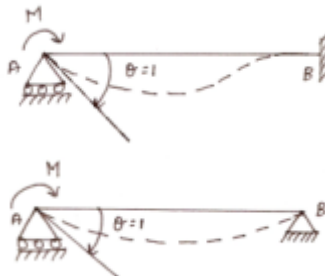

Fig. 5.1

$$K=4 EI/l \text{ (Far end fixed)}$$
$$K=3 EI/l \text{ (Far end hinged)}$$

(c) Carry over:

In moment distribution method, we have to analyse the effects of applying imaginary moments at a specified point.



Fig. 5.2

The beam in the above Fig. 5.2 when it receives a moment M at A , will develop at B a moment of $M/2$. This $M/2$ is called carry over moment. The factor $\frac{1}{2}$ is then the carry over factor. If the far end B were hinged, the carry over factor will be zero.

(d) Distribution factor:

A moment which tends to rotate without translation a joint to which several members are connected will be divided amongst the connected members in proportion to their stiffnesses. The factors $k_i / \sum k$ are called distribution factors.

5.2 STIFFNESS AND CARRY OVER FACTORS

Moment distribution method is an iterative procedure. To start with, all joints in a beam or frame are considered fixed, and the given loading applied on this modified structure. Under this (approximate) condition all the joint moments can be considered as known. These approximate moments are progressively improved and brought as near the true values as desired by considering that:

5.2.1 MOMENT DISTRIBUTION PROCEDURE

1) Simply supported ends cannot have moments. If they have moments (as in the first approximation), these moments shall be removed by applying equal and opposite moments there (called balancing moments).

2) Interior joints cannot have any net moment. If the sum of the moments (SM) at an interior joint is not zero, it is an error. To offset this error, a balancing moment of SM shall be applied at the joint.

3) The balancing moment will be shared by the members connected to the joint in the ratio of their stiffnesses.

4) Now each of the balancing moments introduced in members (in steps 1,2,3 and above) will induce moments at the opposite end of the members as carry over moments.

5) The carry over moments so induced will again spoil the balance achieved in steps 1,2,3 and shall be balanced once again.

6) The process of balancing and carry over shall be carried out till the values of moments involved in balancing are negligible.

The whole process is systematically carried out in a tabular form, and the sum of the moments at each end of each member received in the balancing process and carry over process is taken as the final moment.

5.3 ANALYSIS OF CONTINUOUS BEAMS

Design Procedure:

- 1) Fixed end moments
- 2) Distribution factors
- 3) Moment Distribution
- 4) Shear force diagram
- 5) Bending moment diagram

Example 5.1

Analyse the continuous beam shown in figure by the method of moment distribution.

Fig. 5.3

Solution:

1. Fixed end moments

$$M_{FAB} = - \frac{wl^2}{12} = - \frac{30 \times 6^2}{12} = - 90 \text{ kNm}$$

$$M_{FBA} = + \frac{wl^2}{12} = + \frac{30 \times 6^2}{12} = + 90 \text{ kNm}$$

$$M_{FBC} = - \frac{wab^2}{l^2} = - \frac{40 \times 2 \times 3^2}{5^2} = - 28.8 \text{ kNm}$$

$$M_{FCB} = + \frac{wa^2b}{l^2} = + \frac{40 \times 3 \times 2^2}{5^2} = + 19.2 \text{ kNm}$$

2. Distribution factors

Here A and C are hinged. BA and BC have their far ends hinged. Their stiffness are therefore $3EI/l$. Their stiffness are in the ratio $k_{BA} : k_{BC}$.

Joint	Member	Relative Stiffness, k	Sum	Distribution factor
B	BA	$(3/4) \times (l/6) = (3I)/24$	$(3I)/24 + (3I)/20 = 33I/120$	$(3I/24) / (33I/120) = 5/11$
	BC	$(3/4) \times (l/5) = (3I)/20$		$(3I/20) / (33I/120) = 6/11$

3. Moment distribution:

Line	Joint	A	B		C
1	Member	AB	BA	BC	CB
2	D.F.	---	5/11	6/11	---
3	F.E.M	-90	+90	-28.8	19.2
4	Release A and C and C/O	+90	+45	-9.6	19.2
5	Initial moments	0	135	-38.4	0
6	Balance B	---	-43.9	-52.7	---
7	Final moments	0	91.1	-91.1	0

M_{BA} is +91.1 kNm. This is the moment applied by the support system on BA. M is -91.1 kNm. The BMD is drawn by combining the support moment diagram with the span BMD of BA and BC.

5.3.1 Sinking of supports:

In practical structures such as in Rigid frame bridges, continuous beam bridges, building frames and frames for industrial structures loading can be changed even by sinking of supports or rotation of fixed ends. Support sinks mostly due to soil settlement. Rotation of fixed ends can happen either because of soil settlement or inclined fixed ends. Fixed end moments induced in beam ends because of settlement or rotation of supports BC

Example 5.2

A continuous beam ABCD 20m long is simply supported at its ends and is propped at the same level at B and C as shown. It is loaded as shown. If support B is sinks by 10mm, analyse the beam by moment distribution method and sketch the bending moment diagram. Take $E=2.1 \times 10^5 \text{ N/mm}^2$ and $I=85 \times 10^5 \text{ mm}^4$.

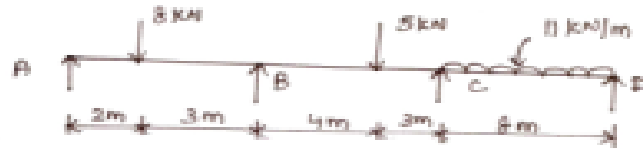

Fig. 5.4

Solution:

Fixed end moments

$$\begin{aligned}
 M_{FAB} &= -\frac{Wab^2}{l^2} - \frac{6EI\delta}{l^2} \\
 &= -\frac{8 \times 2 \times 3^2}{5^2} - \frac{6 \times 2.1 \times 10^8 \times 85 \times 10^{-7}}{5^2} \times \frac{10}{1000} \\
 &= -5.76 - 4.284 = -10.044 \text{ kN/m}^2 \\
 E &= \frac{2.1 \times 10^5}{1000} \times 1000^2 = 2.1 \times 10^8 \text{ kN/m}^2
 \end{aligned}$$

$$I = 85 \times 10^5 \text{ mm}^4 = \frac{85 \times 10^5}{(1000)^4} = 85 \times 10^{-7} \text{ m}^4$$

$$\delta = \frac{10}{1000} \text{ m}$$

$$M_{FBA} = + \frac{Wa^2b}{l^2} - \frac{6EI\delta}{l^2}$$

$$= - \frac{8 \times 2^2 \times 3}{5^2} - 4.284 = -0.444 \text{ kNm}$$

$$M_{FBA} = - \frac{Wab^2}{l^2} + \frac{6EI\delta}{l^2}$$

$$= - \frac{5 \times 4 \times 3^2}{7^2} - \frac{6 \times 2.1 \times 10^8 \times 85 \times 10^{-7}}{7^2} \times \frac{10}{1000}$$

$$= -1.487 \text{ kNm}$$

$$M_{FBA} = + \frac{Wa^2b}{l^2} + \frac{6EI\delta}{l^2}$$

$$= + \frac{5 \times 4 \times 3^2}{7^2} + \frac{6 \times 2.1 \times 10^8 \times 85 \times 10^{-7}}{7^2} \times \frac{10}{1000}$$

$$= +7.084 \text{ kNm}$$

$$M_{FCD} = - \frac{wl^2}{12} = - \frac{1 \times 8^2}{12} = -5.33 \text{ kNm}$$

$$M_{FDC} = + \frac{wl^2}{12} = + \frac{1 \times 8^2}{12} = +5.33 \text{ kNm}$$

2. Distribution factors

Here A and C are hinged. BA and BC have their far ends hinged. Their stiffness are therefore $3EI/l$. Their stiffness are in the ratio $k_{BA} : k_{BC}$.

Joint	Member	Relative Stiffness, k	Sum	Distribution factor
B	BA	$(3/4) \times (I/l) = (3I)/20$	$(3I)/20 + I/7$ $= 41I/140$	$(3I/20) / (41I/140) = 0.512$
	BC	$(I/l) = I/7$		$(I/7) / (41I/140) = 0.488$
C	CB	$I/7$	$I/7 + (3I)/32$ $= 53I/224$	$(I/7) / (53I/224) = 0.604$
	CD	$(3/4) \times (I/8) = (3I)/32$		$(3I/32) / (53I/224) = 0.396$

3. Moment distribution

Joint	A	B		C		D
Member	AB	BA	BC	CB	CD	DC
Distribution factor	---	0.512	0.488	0.604	0.396	---
FEM	-10.044	-0.444	-1.487	7.084	-5.33	+5.33
Release A,D & Carry over	+10.044	5.022			-2.665	-5.33
Initial moments	0	+4.578	-1.487	+7.084	-7.995	0
Balance	---	-1.583	-1.508	+0.550	+0.361	---
Carry over	---		0.275	-0.754	---	---
Balance	---	-0.141	-0.314	0.455	0.299	---
Carry over	---	---	0.228	-0.067	---	---
Balance	---	-0.117	-0.111	0.040	0.027	---
Final moments	0	+2.737	-2.737	+7.308	-7.308	0

4. Simply supported bending moments

$$M_{AB} = \frac{Wab}{l} = \frac{8 \times 2 \times 3}{5} = 9.6 \text{ kNm}$$

$$M_{BC} = \frac{Wab}{l} = \frac{8 \times 2 \times 3}{7} = 8.6 \text{ kNm}$$

$$M_{CD} = \frac{Wl^2}{8} = \frac{1 \times 8^2}{8} = 8 \text{ kNm}$$

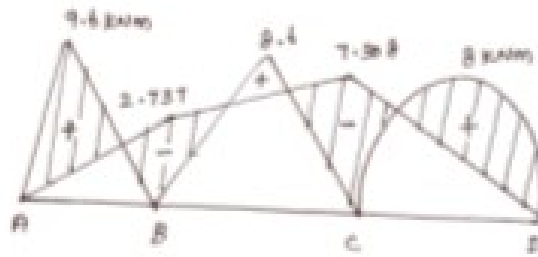

Bending moment diagram(BMD)

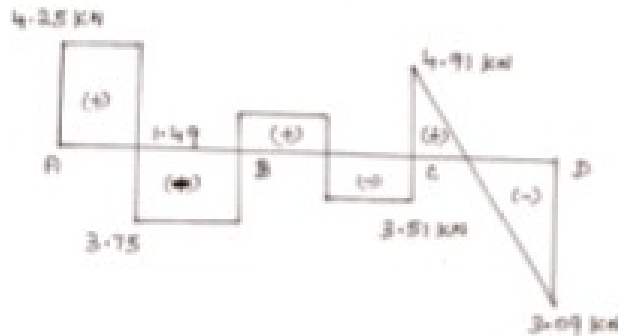

Shear force diagram (SFD)

5.4 PLANE RIGID FRAMES WITHOUT SWAY

The additional feature is that in frames we can have joints with more than two members. Accordingly the relative stiffnesses and distribution factors have to be apportioned. Usually while drawing BMD for continuous beams we draw the free bending moments below the beam centre line and support moments above the beam. This procedure has the advantage of showing the BMD on the tension side of beam. In vertical or inclined members in frame it is difficult to define positive or negative bending moments.

Example 5.3 Analyse the structure loaded as shown in the figure by the moment distribution method and sketch the bending moment and shear force diagrams.

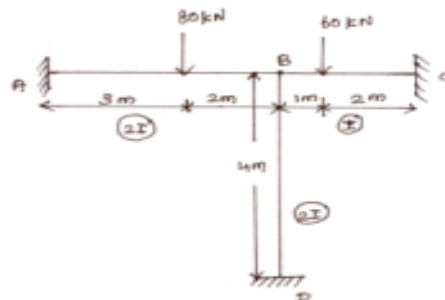

Fig. 5.5

Solution:

1. Fixed end moments:

Span AB:

$$M_{FAB} = -\frac{wab^2}{l^2} = -\frac{80 \times 3 \times 2^2}{5^2} = -38.4 \text{ kNm}$$

$$M_{FBA} = +\frac{wa^2b}{l^2} = +\frac{80 \times 3^2 \times 2}{5^2} = +57.6 \text{ kNm}$$

Span BC:

$$M_{FAB} = -\frac{wab^2}{l^2} = -\frac{60 \times 1 \times 2^2}{5^2} = -26.67 \text{ kNm}$$

$$M_{FBA} = +\frac{wa^2b}{l^2} = +\frac{60 \times 1^2 \times 2}{5^2} = +13.33 \text{ kNm}$$

Span BD:

$$M_{FBD} = M_{FDB} = 0$$

2. Distribution factors:

Joint	Member	Relative Stiffness, k	Sum	Distribution factor
B	BA	2I/5	(2I/5)+(I/2)+(I/3) =37I/30	(2I/5)/(37I/30)=0.324
	BD	2I/4=I/2		(I/2)/37I/30 =0.406
	BC	I/3		(I/3)/(37I/30) =0.270

3. Moment Distribution:

Joint	A	B		C	
Members	AB	BA	BD	BC	CB
Distribution factor	-----	0.324	0.406	0.270	---
Fixed end moments	-38.4	+57.6	0	-26.67	+13.33
Balancing		-10.021	-12.558	-8.351	
Carry over	-5.011				-4.176
Final moments	-43.411	47.579	-12.558	-35.021	+9.154

$$M_{DB} = \frac{1}{2}(-12.588) = -6.279 \text{ kNm}$$

4. To draw S.F.D.:

Span AB:



Taking moments about A,

$$R_B(5) + M_{AB} - W(a) - M_{BA} = 0$$

$$R_B(5) + 43.411 - 80 \times 3 - 47.579 = 0$$

$$R_{B1} = 48.834 \text{ kN}$$

$$R_A = \text{Total load} - R_B = 80 - 48.834$$

$$R_A = 31.166 \text{ kN}$$

Span BC:

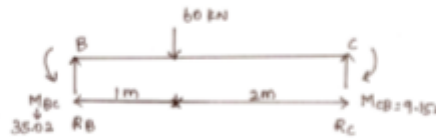

Taking moments about B,

$$R_C(3) + M_{BC} - M_{CB} - W(a) = 0$$

$$R_C(3) + 35.021 - 9.154 - 60(1) = 0$$

$$R_C(3) + 35.021 - 9.154 - 60(1) = 0$$

$$R_C = 11.378 \text{ kN}$$

$$R_{B2} = 60 - 11.378 = 48.622 \text{ kN}$$

Span BD:

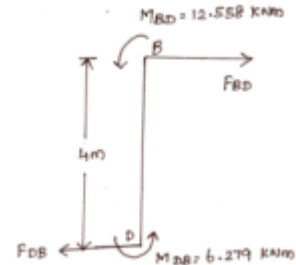

Taking moments about D,

$$F_{BD}(4) - M_{BD} - M_{DB} = 0$$

$$F_{BD}(4) - 12.558 - 6.279 = 0$$

$$F_{BD} = 4.709 \text{ kN}(\rightarrow)$$

$$F_{DB} = 4.709 \text{ kN}(\leftarrow)$$

5. Simply supported bending moments:

$$\text{Span AB} = \frac{Wab}{l} = \frac{80 \times 3 \times 2}{5} = 96 \text{ kNm}$$

$$\text{Span BC} = \frac{Wab}{l} = \frac{60 \times 1 \times 2}{3} = 40 \text{ kNm}$$

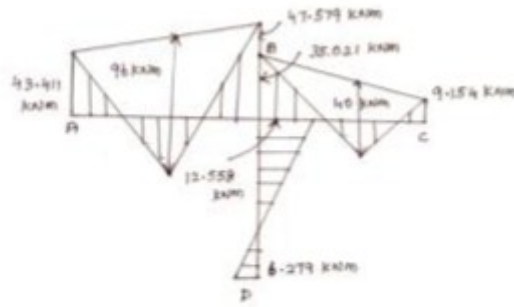

Bending moment diagram (BMD)

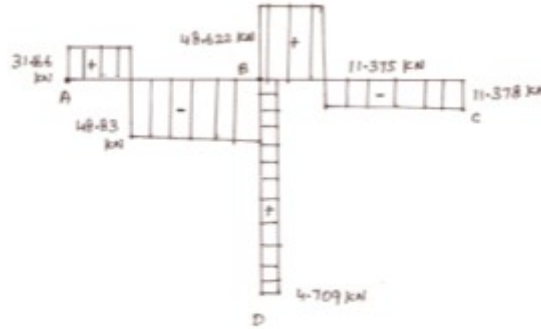

Shear force diagram (SFD)

5.5 PLANE RIGID FRAMES WITH SWAY

Concept of sway: All practical frames are liable to sway, be they multistoried building frames, industrial building frames or bridge frames. Sway is the phenomenon of lateral movement of a structural frame. Due to sway a set of bending moments will get developed in the beams and columns in a frame.

DESIGN PROCEDURE:

- Step: 1** Calculation of fixed end moments
- Step: 2** Calculation of Distribution factors
- Step: 3** Side sway analysis
- Step: 4** Moment distribution
- Step: 5** Sway forces
- Step: 6** Shear force diagram
- Step: 7** bending moment diagram

Example 5.4 Analyse the portal frame loaded as shown in figure by the moment of distribution method and sketch the BMD and SFD.

Solution:

(a)Fixed end moments:

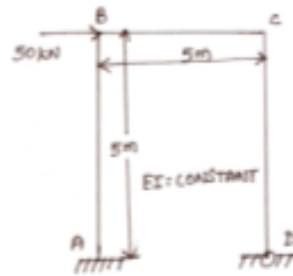
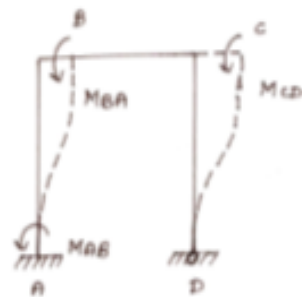

Fig. 5.6

Span AB, BC, CD: $M_{FAB}=M_{FBA}=M_{FCB}=M_{FCD}=M_{FDC}=0$.

Since the load is acting only at the joint, there will be no fixed end moments. However due to side sway, moments will be induced at joints A, B and C.



(b)Distribution factors:

Joint	Member	Relative Stiffness, k	Sum	Distribution factor
B	BA	$I/5$	$I/5+I/5=2I/5$	$(I/5)/(2I/5) = 1/2$
	BC	$I/5$		$(I/5)/(2I/5) = 1/2$
C	CB	$I/5$	$(I/5)+(3I)/20 = 7I/20$	$(I/5)/(7I/20) = 4/7$
	CD	$(3/4) \times (I/5) = (3I)/20$		$(3I/20)/(7I/20) = 3/7$

(d) Moment distribution:

Joint	A	B		C		D
Member	AB	BA	BC	CB	CD	DC
Distribution factor	---	1/2	1/2	4/7	3/7	---
FEM	-20	-20	---	---	-10	---
Balancing		10	10	5.71	4.29	
Carry over	5		2.86	5		
Balance		-1.43	-1.43	-2.86	-2.14	
Carry over	-0.72		-1.43	-0.72		
Balance		0.72	0.72	0.41	0.31	
Carry over	0.36		0.21	0.36		
Balance		-0.11	-0.11	-0.21	-0.15	
Carry over	-0.06		-0.11	-0.06		
Balance	0.06	0.05	0.06	0.03	0.03	
Final moments	-15.42	-10.76	10.77	7.66	-7.66	0

(e) Sway forces:

Balancing moment for AB = $10.76 + 15.42 = 26.18$

Horizontal reaction at B = $(26.18)/5 = 5.24 \text{ kN}(\rightarrow) = H_{BA}$

Horizontal reaction at A = $5.24 \text{ kN}(\leftarrow) = H_{AB}$

Balancing moment for CD = 7.66 kNm

Horizontal reaction at C = $(7.66)/5 = 1.53 \text{ kN}(\rightarrow)$

Horizontal reaction at D = $1.53 \text{ kN}(\leftarrow)$

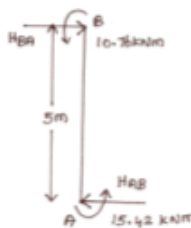

The sway force causing the assumed moments = $5.24 + 1.53 = 6.77 \text{ kN}(\leftarrow)$

But actual sway force is 50 kN . hence the moments be increased proportionately in the ratio of $50/6.77 = 7.38$.

Joints	A	B		C		D
Hsway = 6.77 kN	-15.42	-10.76	10.76	7.66	-7.66	0
Hsway = 50 kN	-113.8	-79.41	79.41	56.53	-56.53	0

Horizontal reaction at A = $5.24 \times 7.38 = 38.67 \text{ kN}$

Horizontal reaction at D = $1.53 \times 7.38 = 11.29 \text{ kN}$

(f) To draw S.F.D.

Span AB:

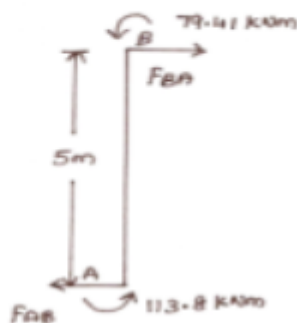

Taking moments about A, $-79.41 - 113.8 + F_{BA}(5) = 0$

$$F_{BA} = 38.642 \text{ kN} = F_{AB}$$

Span BC:

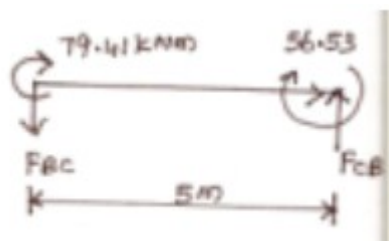

Taking moments about B, $+79.41 + 56.53 - F_{CB}(5) = 0$

$$F_{CB} = 27.19 \text{ kN} = F_{BC}$$

Span CD:

Reaction at D = $11.29 \text{ kN} \downarrow$

Reaction at C = $11.29 \text{ kN} \uparrow$

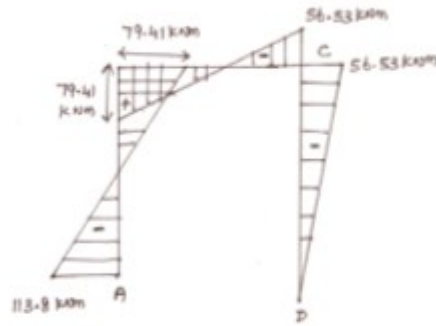

Bending moment diagram (BMD)

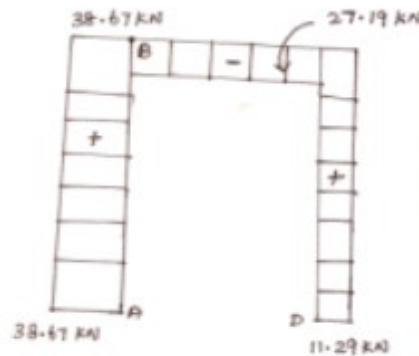

Shear force diagram (SFD)

5.6 NAYLOR'S SIMPLIFICATION (Cantilever Moment Distribution)

The process of moment distribution ensures that all joints originally assumed to be fixed are allowed to rotate sufficiently to let each joint in moment equilibrium. Cantilever moment distribution is a method suited to frames, especially multistory frames. Cantilever moment distribution is geared to tackle only symmetric frames, with anti-symmetric loads. In this method sway analysis is completely avoided.

Redefining the basic terms:

The terms fixed end moment, stiffness and carry over need to be redefined in the case of cantilever moment distribution method.

- (i) The fixed end moments on columns are computed from the justifiable assumption that columns have zero bending moments at mid heights.
- (ii) Carry over
- (iii) Stiffness

QUESTION BANK

PART-A

1. What are the advantages of slope-deflection method over moment distribution method?
2. What is meant by relative stiffness of a member?
3. Define carry over factor?

4. Define distribution factor and carry over factor in moment distribution method.
5. Explain the terms 'distribution factor' and 'carry over factor'
6. State stiffness of a member.
7. Define distribution factor.
8. What is relative stiffness?
9. Write the three moment equation for general case.
10. Determine the fixed end moment of the beam shown in fig.

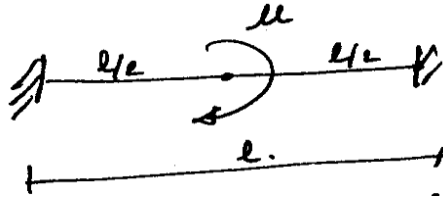

11. Define Stiffness factor.
12. What do you mean by carry over factor?
13. Write the expression for fixed end moment for a beam subjected to sinking of support by an amount.
14. Give the carry over factor of a bending member when the far end is (i) hinged (ii) fixed.
15. State the advantages of continuous beam over simply supported beam.

PART-B

1. Draw the bending moment diagram and shear force diagram for the continuous beam shown in figure below using moment distribution method. EI is constant.

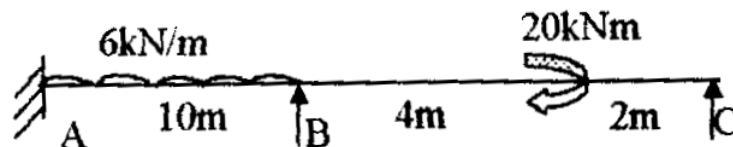

2. Analysis the frame shown in figure below for a rotational yield of 0.002 radians anticlockwise and vertical yield of 5 mm downwards at A . assume $EI = 30000 \text{ kNm}^2$. $I_{AB} = I_{CD} = I$; $I_{BC} = 1.5I$. Draw bending moment diagram. Use moment Distribution Method.

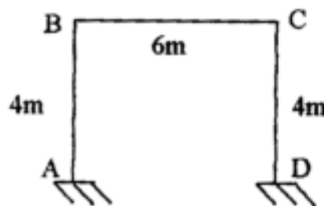

3. Draw the bending moment diagram and shear force diagram for the continuous beam shown in figure below using moment distribution method. EI is constant.

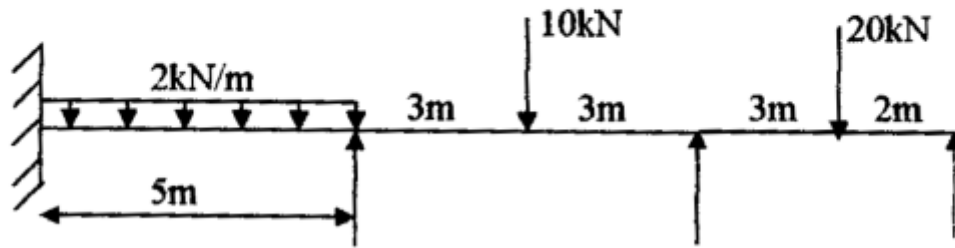

4. Draw the bending moment diagram and shear force diagram for the continuous beam shown in figure below using moment distribution method. EI is constant.

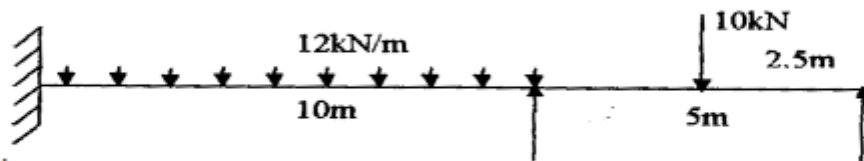

5. A continuous beam ABCD is fixed at A and simply supported at D and is loaded as shown in figure 3 spans AB, BC and CD have MI of I, I-SI, and I respectively. Using moment distribution method. Determine the moment at the supports and draw the BMD.

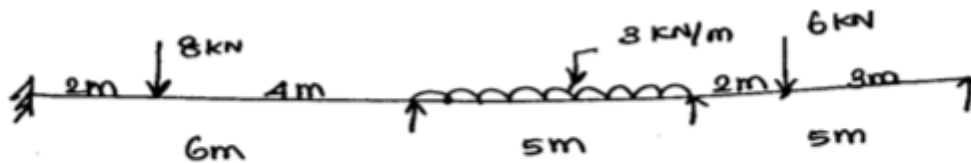

6. Analyse and draw the BMD for the frame shown in figure. Using moment the frame has stiff joint at B and fixed at A, C and D.

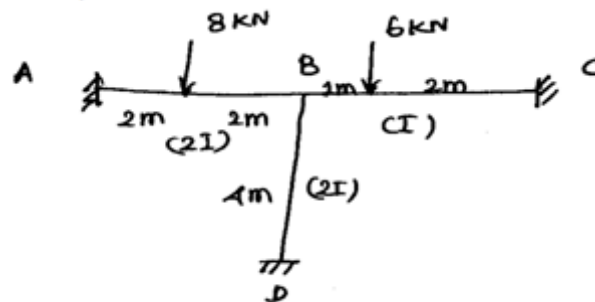

7. A beam ABCD, 16m long is continuous over three spans AB=6m, BC = 5m & CD = 5m the supports being at the same level. There is a udl of 15kN/m over BC. On AB, is a point load of 80kN at 2m from A and CD there is a point load of 50 kN at 3m from D, calculate the moments by using moment distribution method. Assume EI const.

8. A continuous beam ABCD 20m long carried loads as shown in figure. Find the bending moment at the supports using moment distribution method. Assume EI const.

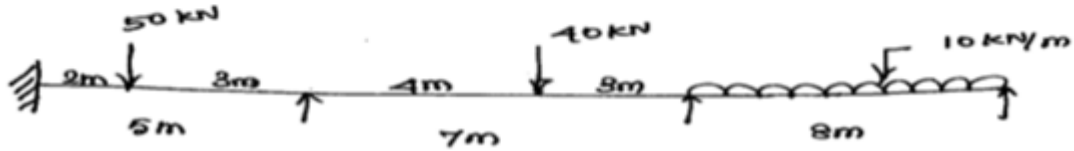

9. Analyse a continuous beam shown in figure by Moment distribution method. Draw BMD.

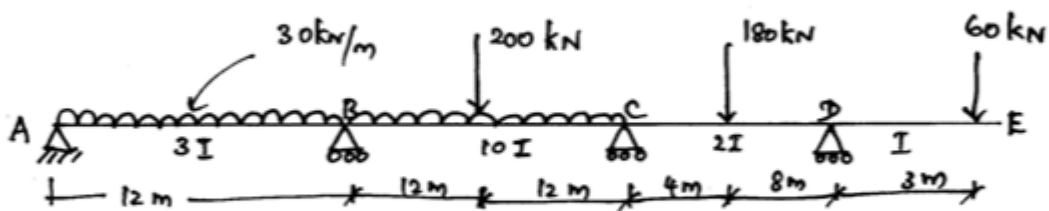

10. Using Moment Distribution method, determine the end moments of the members of the frame shown in figure EI are same for all the members.

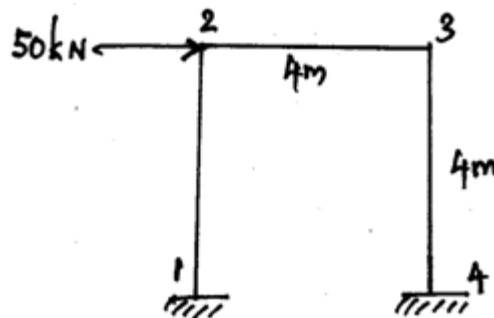

11. A continuous beam ABCD consists of three spans and is loaded as shown in figure. Ends A and D are fixed. Determine the bending moments at the supports and plot the bending moment diagram.

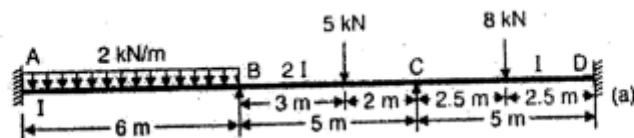

12. Analyze the continuous beam loaded as shown in figure by the method of moment distribution. Sketch the bending moment and shear force diagrams.

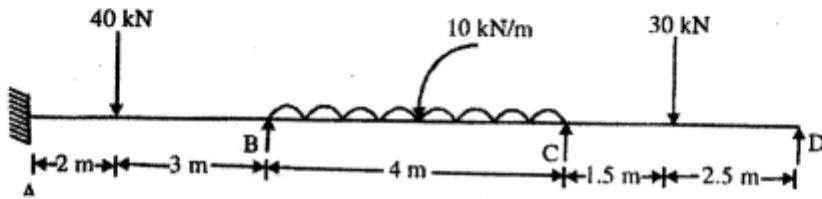

13. A stiff jointed frame ABCD is of constant section throughout and has the following dimensions. $AB=4.5\text{m}$, $BC=3\text{m}$ and $CD=1.8\text{m}$. It carries loads of 600kN each at each of the third points of the horizontal beam BC. The legs AB and CD are vertical. Calculate the moments at the joints if the feet are fully fixed. Use moment distribution method.